

## Design Features

- **RMA Axial Check Valves** type „CKR“ are fully welded.
- the body and the disc are designed for a pressure loss as small as possible.
- the spring is designed for a quick reaction in case of flow changes.
- the sealing is metal-to-metal with hard faced stainless steel sealing surfaces.
- a buffer system is integrated to avoid noisy closing (opening)
- the dimensions are acc. to API 6D
- Axial check valves are designed for horizontal position. Vertical position is possible by using a special spring.

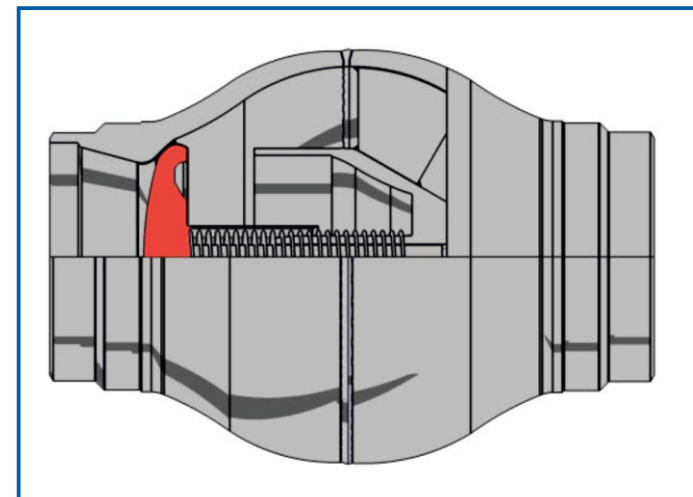

*Check valve in closed position*

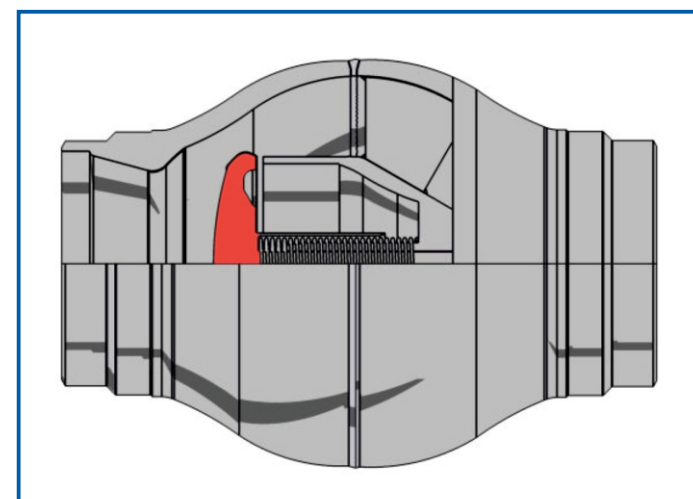

*Check valve in open position*